

# # SPEC DWG

#8303-48-AS Ground Sleeve for 3-1/2" O.D. W/ Neoprene Cap

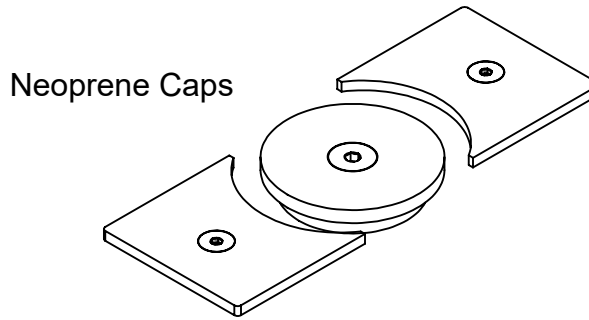
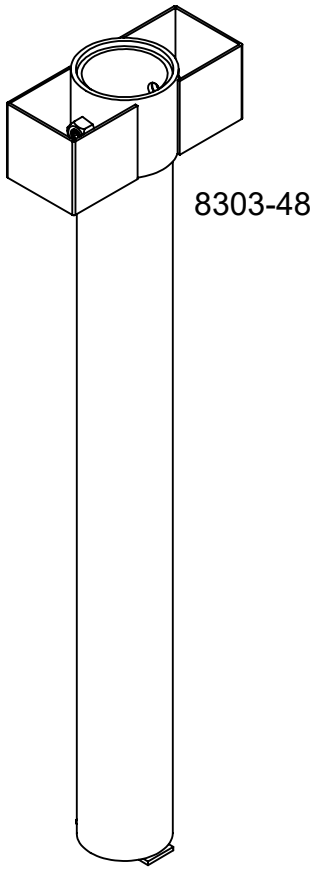

SPECIFICATIONS: General: Game post sleeves permit removal of posts.

Materials: Sleeves are fabricated from ASTM A36 rated steel.

Neoprene Cap (N): Heavy neoprene rubber disc expands to seal top of sleeve when a socket head bolt is tightened causing compression of rubber. Making a weather resistant seal. Top of cap is heavy galvanized plate with counter sunk hole.

Warranty: 3 years

	Date: 8/6/20	<b>SPECIFICATION / INSTALLATION INSTRUCTIONS</b>
	Rev:	
	Drawn: JBN	MODEL NO.
	Sheet: 1 of 2	#8303-48-AS

## Recomended Footing Detail

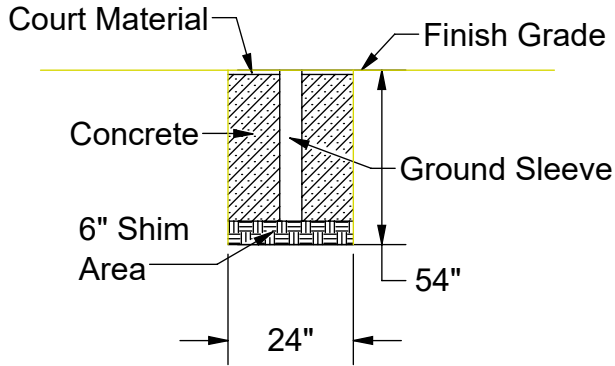

**INSTALLATION INSTRUCTIONS:**

Dig recommended size hole(s) per sleeve detail. Put a minimum 6" layer of gravel in the bottom of the hole to allow for drainage.

Center sleeve in hole. Make certain bottom of sleeve is in contact with gravel so that bottom of sleeve will not be plugged with concrete. Add additional gravel if necessary to sleeve location to ensure correct height.

Sleeve(s) should be located so that the top of the sleeve is flush with the court surface.

Pour concrete to top and trowel smooth, crown slightly to allow water to drain away from sleeve. Allow concrete to set for approximately 3 days.

Note: Footing sizes are based on average soil conditions. Loose and/or sandy soil is not average and footing sizes must be increased accordingly to meet local soil conditions.

Set screws can be tightened to hold game post once proper alignment with game surface is insured.

 <p><b>ATHLETIC MFG. CO.</b></p>	Date: 8/6/20	<b>SPECIFICATION / INSTALLATION INSTRUCTIONS</b>  <b>3-1/2"x 48" Ground Sleeve</b>
	Rev:	
	Drawn: JBN	MODEL NO.
	Sheet: 2 of 2	<b>#8303-48-AS</b>

# Pick Ticket

Description	Qty.
8303-48-AS	
3-1/2" I.D. Sleeve 51" Long	1
1/4" Steel Cap Center	1
1/4" Steel Set Screw Cap	2
3/8"x1-1/4" Flat Head Bolt	3
3/8" Fender Washer	3
3/8" Nyloc Nut	3
Neoprene Center Cap	1
Neoprene Set Screw Cap	2

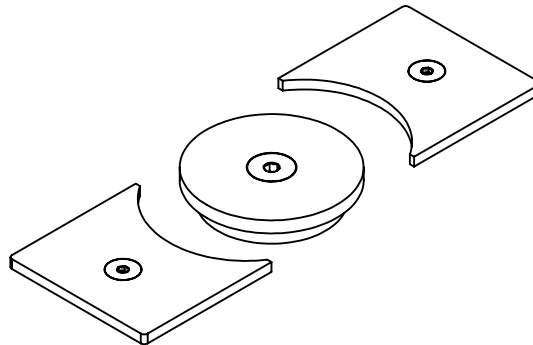
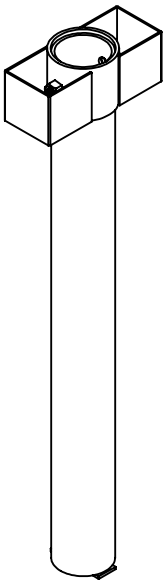

Date: 8/6/20

Rev:

Drawn: JBN

Sheet: 3 of 3

## SPECIFICATION / INSTALLATION INSTRUCTIONS

3-1/2"x 48" Ground Sleeve

MODEL NO.

#8303-48-AS